

INDEX	Gearbox type CE	CE002-e
-------	--------------------	---------

		PAGE
1.	<b>Gearbox structure</b>	2
1.1	Versions	2
1.2	Outlet shaft bearing	3
2.	<b>Setting at work</b>	4
2.1	Advices for transportation	4
2.2	Data number plate	4
2.3	Conditions at delivery	5
2.4	Technical data	6
2.5	Operation running condition	7
2.6	Main motor specification	9
2.7	Assembling position and lubrication	10
2.8	Gearbox motor connection and assembly	14
2.9	Electrical section	16
3.	<b>Maintenance</b>	18
3.1	Lubrication and control	18
3.2	Failures research and repairs	19
3.3	Disassembly / assembly	21
3.4	Spare parts list	29

1. Gearbox structure	Gearbox type CE	CE002-e
----------------------	-----------------	---------

1. Gearbox structure

1.1 Versions

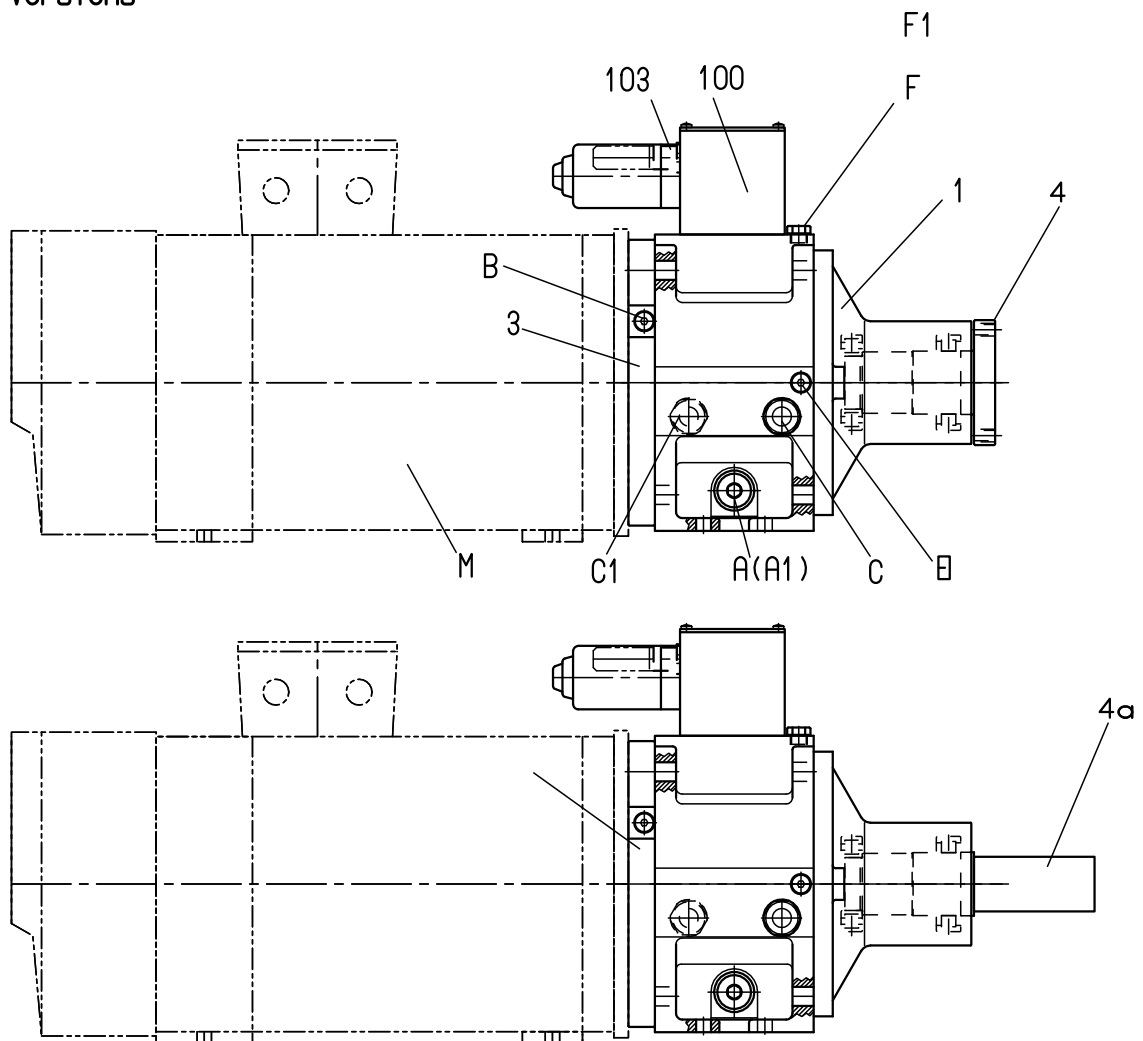

\*B = oil input, with recirculating lubrication, for inlet elements

\*E = oil input; with recirculating lubrication, for central and outlet units

\*F1 = oil loading plug and vent valve

\*C/C1 = Oil pressure warning

\*A/A1 = oil discharge

1 = Casing

3 = Flange

4 = Flange output

4a= shaft output

100 = actuator and data number plate

103 = electrical connector

M = Motor

The motor(M) is fixed on the gearbox casing (1) through the interposition of the flange(3); for some versions, this constitutes only a center square element, therefore is not visible. The casing (1) is normally fixed on the machine. On the output shaft (4) or (4a) is normally fixed the pulley for the motion transfer. The electrical connection has to be made on the connector (103)

The indicated function with(\*), must be made only for OPP orizontal assembly position. For other assembly position see chapter 2.7.



Edition	Revision ..
October 2004	.....



1. Gearbox structure	Gearbox type CE	CE002-e
----------------------	-----------------	---------

## 1.2 Output shaft bearings

In the table 1 are indicated the bearings mounted on the output shaft with the related loading capacity values.

These elements, added to the data on table 2, allow to determinate the bearings life in function of the resulting load  $F_a$  of its position and of the n.p.m.

Table 1

Gearboxes	BEARING X		BEARING Y	
	Type	Basic load Ratings dynamic N	Type	Basic load Ratings dynamic N
CE 13	NUP210ECP	69500	NU2210ECP	78100

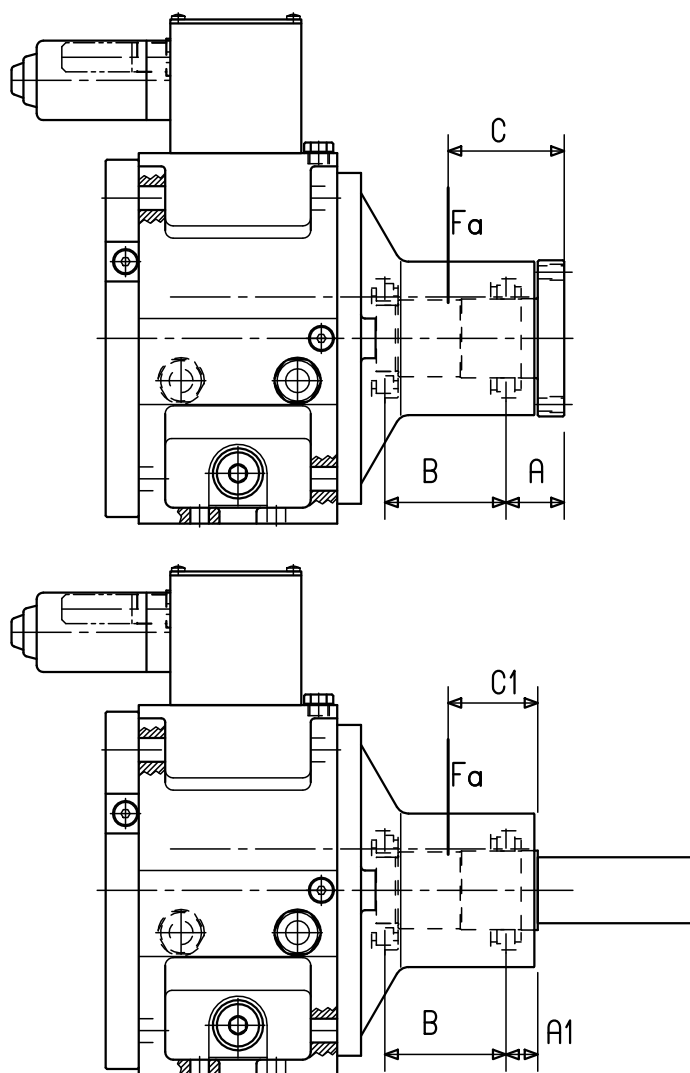

Table 2

mm	CE13
A	44
A1	24
B	91,5
C	55-95
C1	35-75

$F_a$  = Resulting radial force  
in the other words belt-pull

C and C1 indicate the suggested position of  $F_a$  force



2. Setting at work

2.1 Advices for the transportation

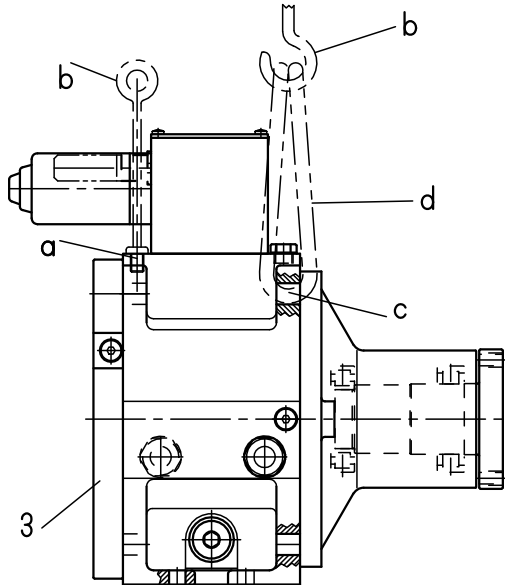

- a = Hole for eyebolt
- b = Eyebolt (excluded for the supply)
- c = Lifting eyebolt  
(reciprocated to hole a)
- 3 = Flange
- d = Lifting cord

Table 3

GEARBOX	Dimension hole for eyebolt	Weight of the gearbox (KG)
CE 13	M 10	68-86 <small>It depends by the size of the flange</small>

2.2 Data plate

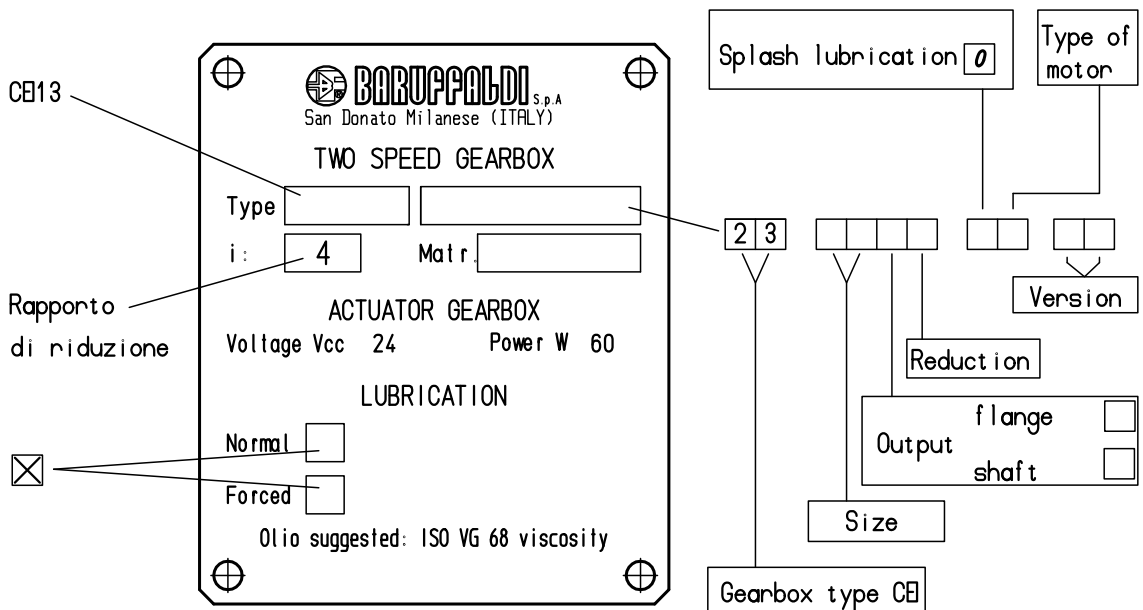

### 2.3 Condition at delivery

Further to the instruction manual the gearbox is delivered with:

- Flange (3) corresponding to the ordered motor complete with rotating seal (32)
- Pinion (2) corresponding to the ordered motor
- Insert (22) for balancing
- Electrical connector (103) complete with the plug and corresponding pins

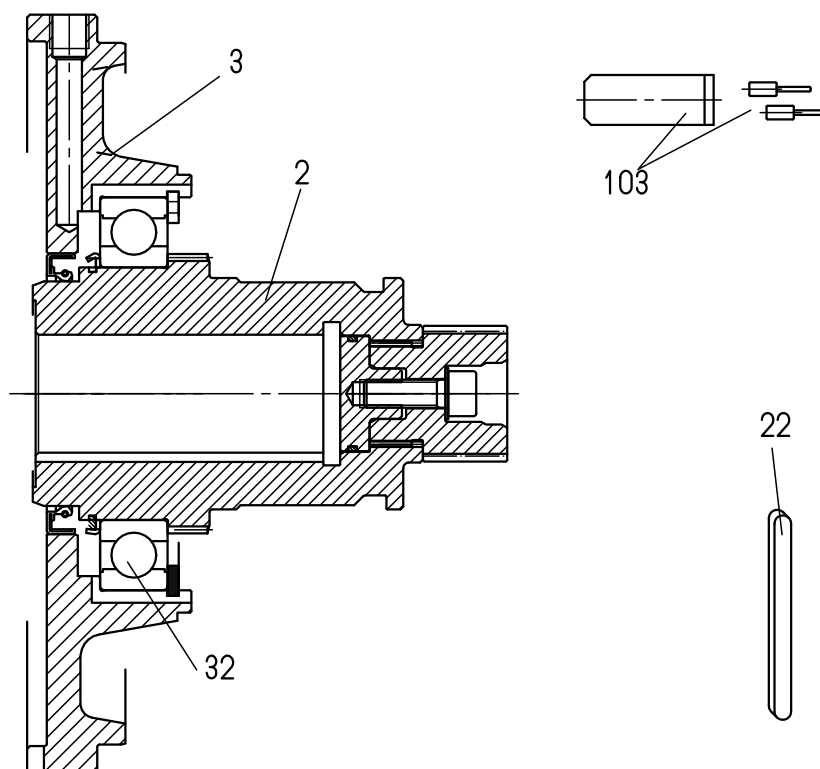

At the delivery the gearbox is engaged with the reduction speed



The gearbox is delivered without oil: before the put in function provide to fill it or to install the forced lubrication as described in chapter 3.1.

## 2.4 Technical data

Size	CE 13	
	(i = 4)	
Nominal rating KW	40	40
Nominal torque inlet Nm	260	260
MAX torque inlet Nm	400	400
Nominal torque outlet i = 1:1 Nm	260	260
Nominal torque outlet Nm	i=4	1040
	i=4.4	1140
* Max number of revolution inlet (rpm)	7000	7000
Moment of inertia of the masses referred to the inlet (kg*cm <sup>2</sup> )	i = 1	
	i = 4	
	i=4.4	

\* See the chapter 2.7 ( assembly position and lubrication)

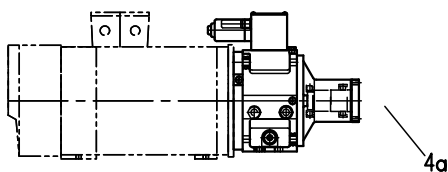
The outlet shaft (4a) of the gearboxes type 2  
is balanced with half key

Codice:

		2		
--	--	---	--	--

## 2.5 Operating running condition

The actuator (100), through the fork (11), has the function to move the sliding sleeve (5) to engage on the pinion (2) or the fixed crown (6). The ratio is fixed by the position of the sliding sleeve.

M = Motor

2 = Pinion (connected to the motor M)

5 = Sliding sleeve

11 = Fork

6 = Fixed crown

100 = Actuator

7 = Gear

10 = Planetary gears

9 = Planetary gears carrier (connected to the output shaft 4)

4 = Output shaft

8 = Solar gear

Picture 1

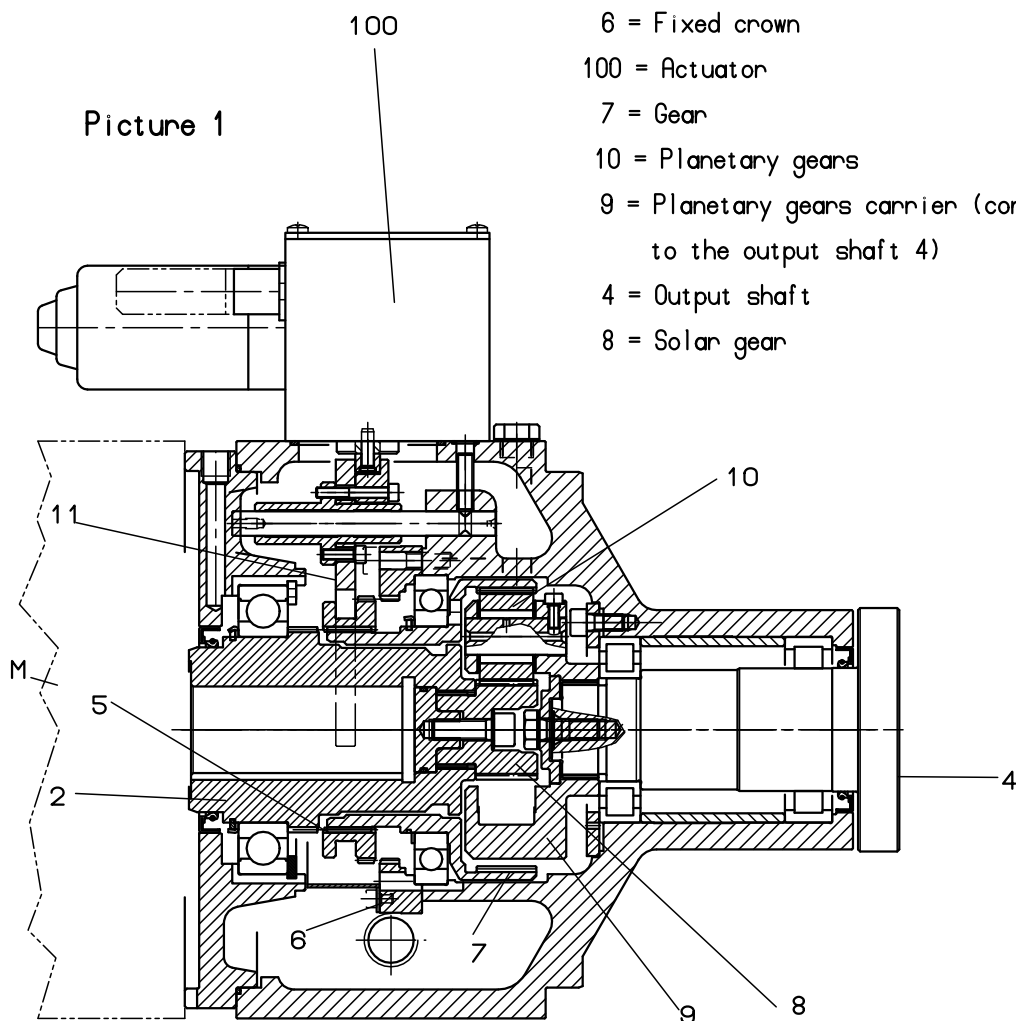

## 2.5.1 Gearbox in neutral position pic.1

The sliding sleeve in central position, disengaged either from the pinion (2) or from the crown (6). The motor (M), through the pinion (2), transmits the rotation to the solar gear (8) which through the planetaries (10), brings in rotation the gear (7) while the planetary gears carrier (9) and the output shaft (4) are not interested in the rotation except a limited dragging due to the frictions.

2. Setting at work	Gearbox Type CE	CE002-e
--------------------	--------------------	---------

### 2.5.2 Gearbox in ratio 1:1 (pic2)

Sliding sleeve (5) engaged with the pinion (2).

The pinion (2), connected to the solar (8) and integral, through the sliding sleeve (5) , to the gear (7), transmits the motor rotation (M) to the planetary gears carrier (9) and thus to the output shaft (4) with ratio 1:1.

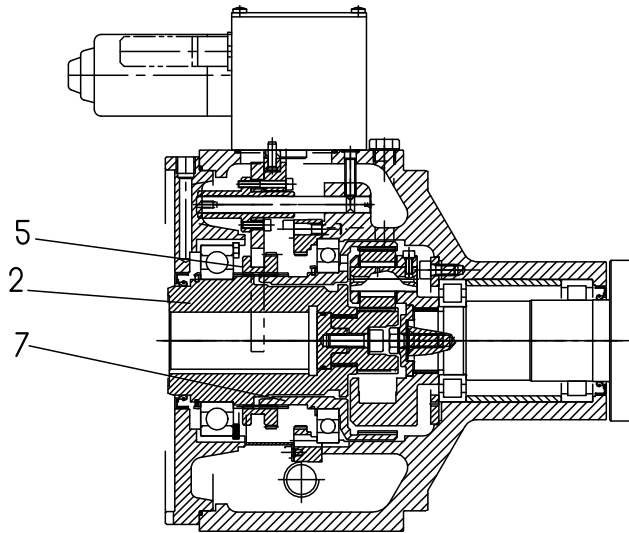

Pic.2

### 2.5.3 Gearbox in reduction (pic.3)

The sliding sleeve (5) engaged with the fixed crown (6) stops the rotation of the gear (7). The motor (M) through the pinion (2) and the solar gear (8), brings in rotation the planetary gears (10), which by rotating in the internal tothing of the locked gear (7) put the planetary gears carrier (9) in rotation and thus the output shaft with ratio in reduction.

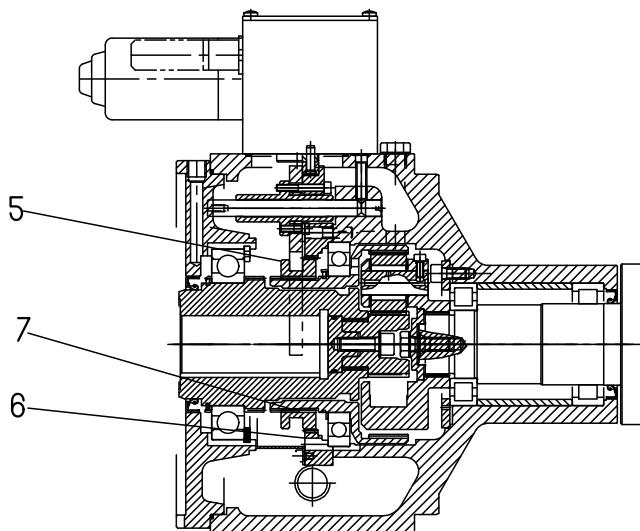

Pic.3

## 2.6 Main motor specifications

The motor which has to be applied to the gearbox has to be in accordance with the following specifications:

- Dimensions and power admitted by the gearbox
- Motor form B3/B5 for horizontal assembly positions (in order to reduce flexions and vibrations the motor has to be supported in the back side)
- Motor form V1/V3 for vertical assembly positions
- Motor without seal on the shaft
- Tolerances TA/TB/TC as per DIN 42955R
- Vibration level R.

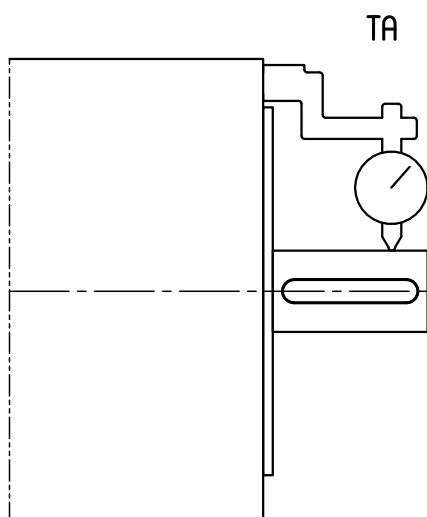

Tolerance DIN 43955R

Dimension motor	TA mm	TB mm	TC mm
112	0.025	0.050	0.050
132	0.025	0.063	0.063
160	0.030	0.063	0.063

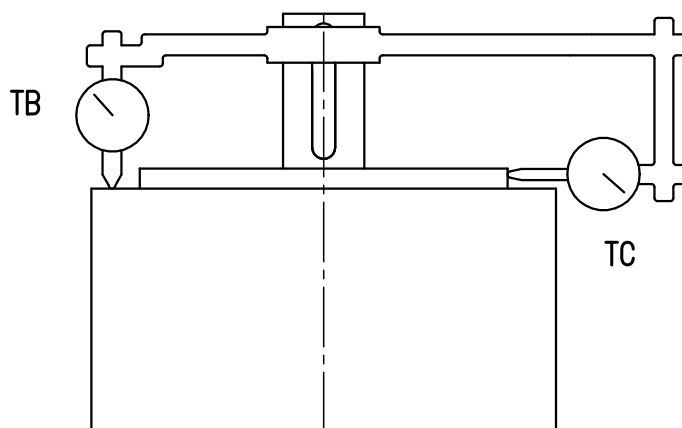

## 2.7 Assembly positions and lubrication

The different assembling positions define also the ways of lubricating.

For horizontal (OPP OPD OPS) and downwards vertical (VPB VFB) installation, it is required splash-lubrication - with temperature restrictions. The gear stands temperatures up to 120°C (110°C for oil), without problems, if it is assumed an excessive heat while working - constant high number of revolutions - the it is required an oil recirculating lubrication. For upwards - vertical installation (VPA VFA) - lubrication must be with recirculating oil.

The use of the forced lubrication for any assembling position helps to take out the heat from the gearbox. If the use foresees low temperature levels the forced lubrication could be integrated with the installation of a heat exchanger in order to cool the oil outside the gearbox. To define better the measurements necessary to the loss of heat we suggest to analyze the problem during the test of the machine, because the heat which is generated it depends from the speed and the time of functioning.

The gearbox can stand, without troubles, at temperatures up to 100°C (oil 90°C).

Oil recirculating lubrication can effected either when the housing is dry or when is wet. If effected when housing is dry - which is more effective to removing heat - oil flux must be constantly checked.

If effected when the housing is wet - which is less effective to removing heat - oil flux must be checked, but not constantly.

An intermediate solution could be to use the recovery holes scheduled for dry housing, and manually raise the oil discharging level, so that all the important elements of the gear can at all times be lapped by it.



### 2.7.1 Service holes

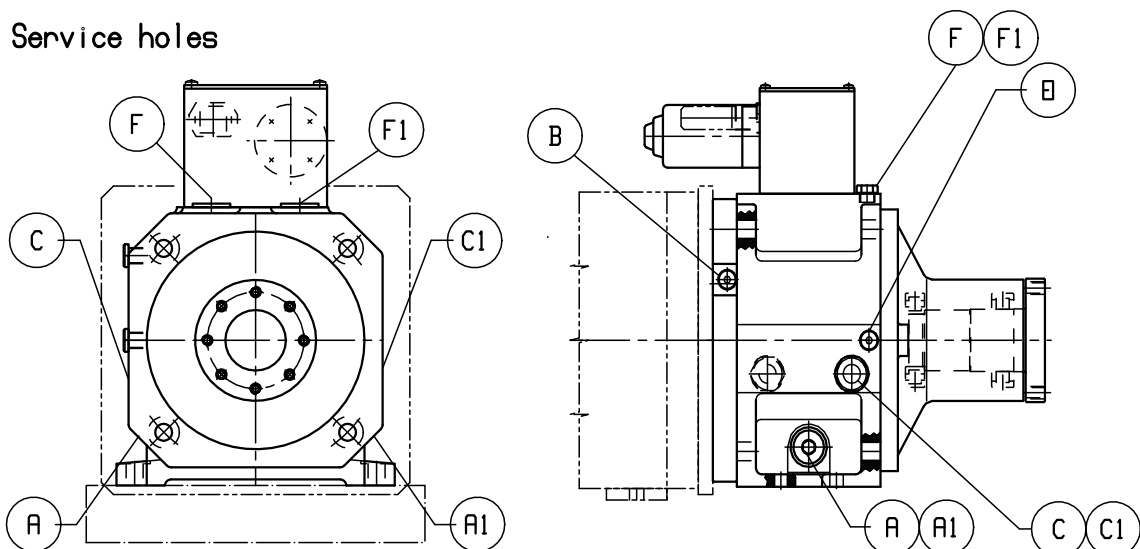

SIZE	A/A1	B	C/C1	E	F/F1
CE13	3/4" G	1/4" G	3/4" G	1/4" G	3/8" G

2.7.2 Horizontal assembly positions and splash lubrication:

- Assembling position OPP

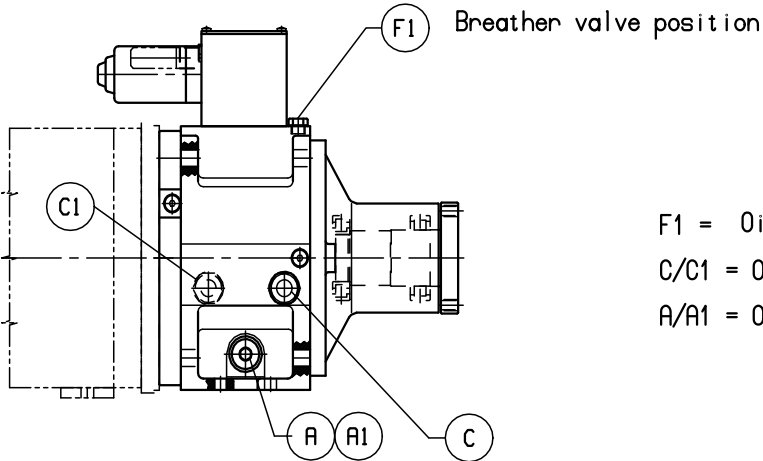

F1 = Oil loading plug / vent valve  
C/C1 = Oil level  
A/A1 = Oil drain plug

- Assembling position OPD

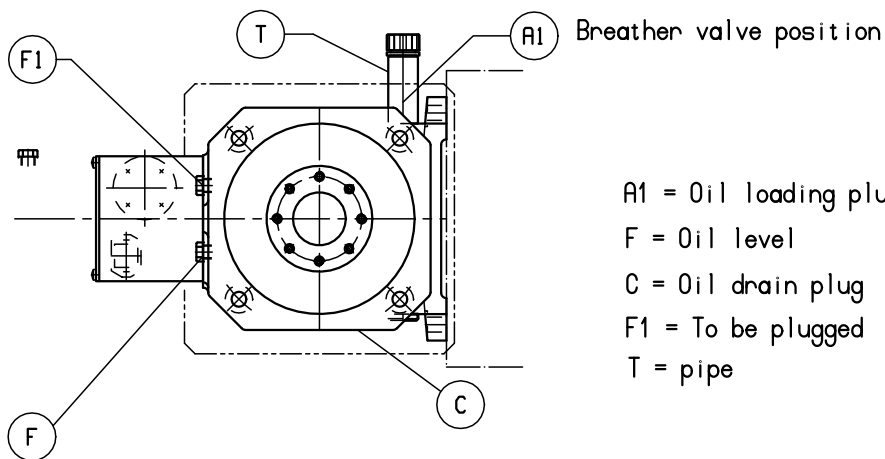

A1 = Oil loading plug / vent valve  
F = Oil level  
C = Oil drain plug  
F1 = To be plugged  
T = pipe

- Assembling position OPS

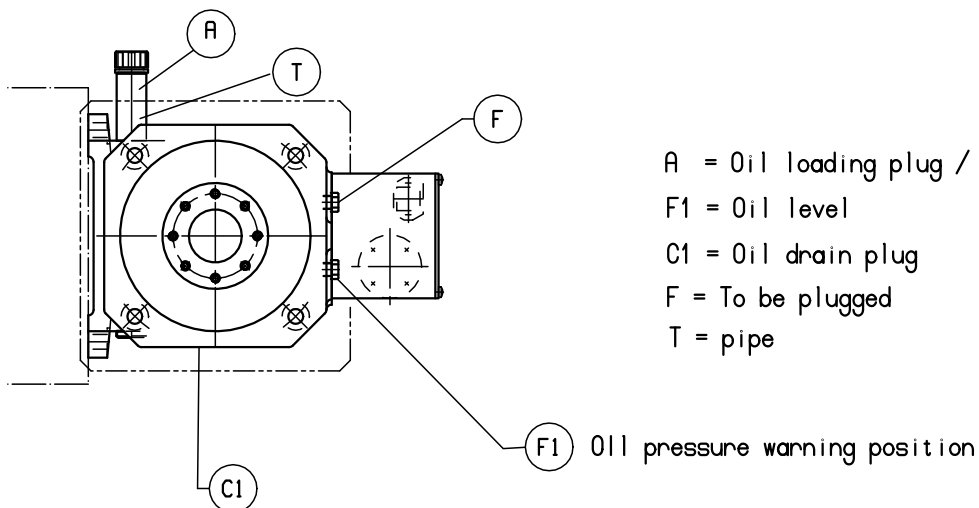

A = Oil loading plug / vent valve  
F1 = Oil level  
C1 = Oil drain plug  
F = To be plugged  
T = pipe

## 2.7.3 Vertical installation and splash-lubrication:

- VPB - VFB installations

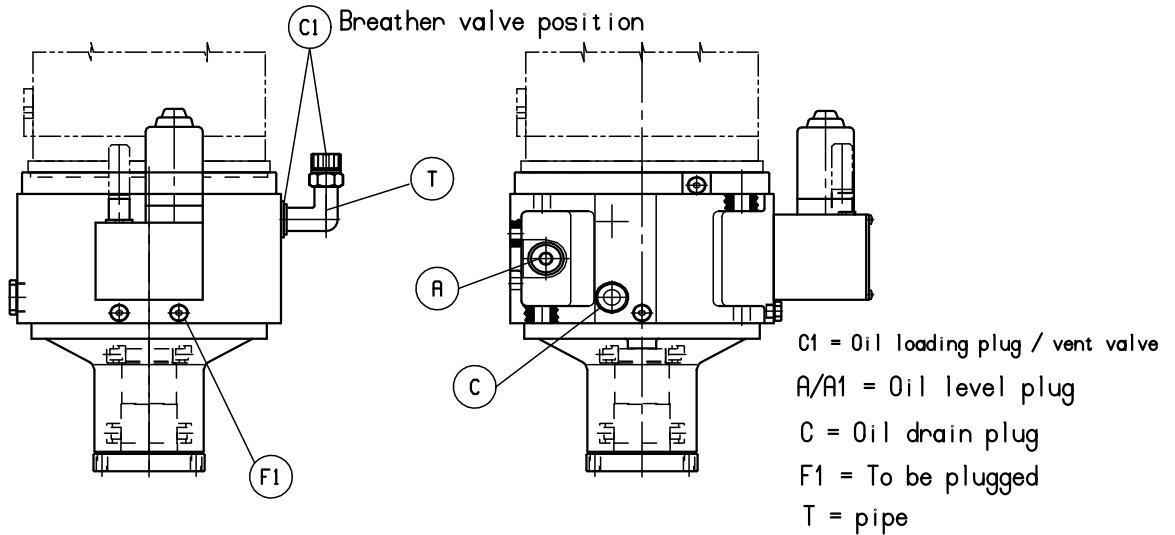

## 2.7.4 Horizontal assembling position and forced lubrication:

- OPP assembling position

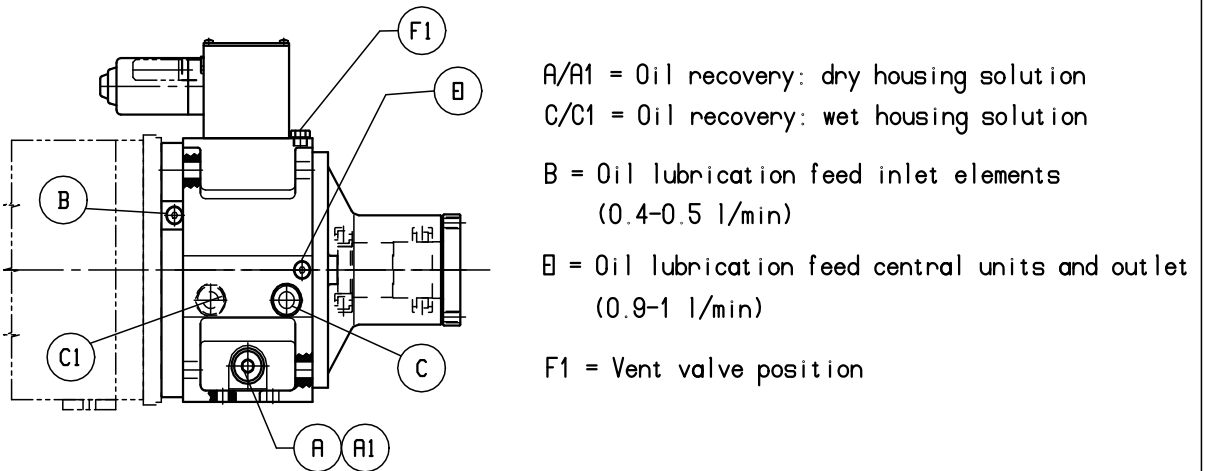

- OPD assembling position

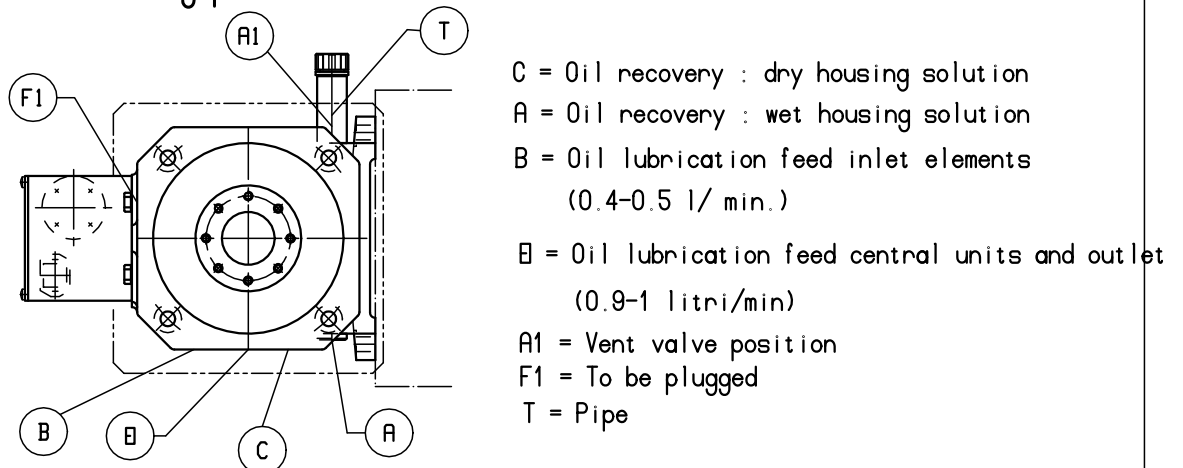

## - OPS assembling position (forced lubrication)

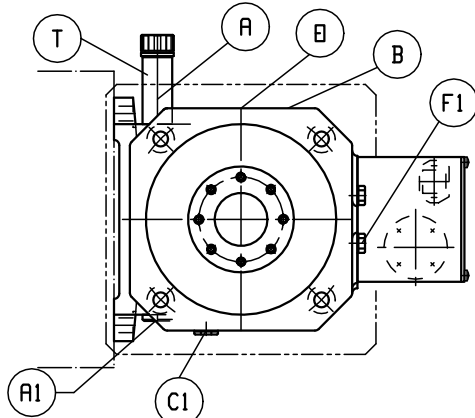

C1 = Oil recovery : dry housing solution

A1 = Oil recovery : wet housing solution

B = Oil lubrication feed inlet elements  
(0.4-0.5 l/ min.)E = Oil lubrication feed central unit and outlet  
(0.9-1 litri/min)

A = Vent valve position

F1 = To be plugged

T = Pipe for vent valve

## 2.7.5 Vertical assembling position and forced lubrication

## - Assembling VFA/VPA (motor below and output to the high)

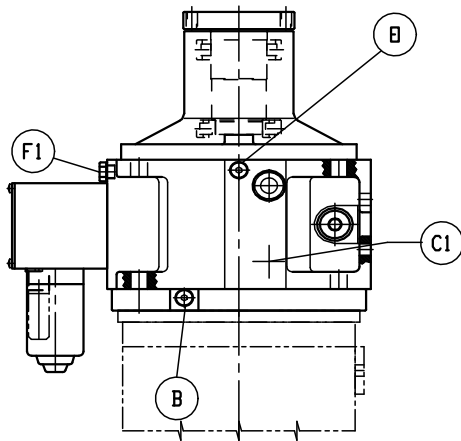

E = Oil suction for lubrication (1.5 l/min)

F1 = Vent valve position

C1 = Oil recovery by falling

D = Oil recovery by aspiration

## - VPB/VFB assembling position (motor on the top and gearbox output below)

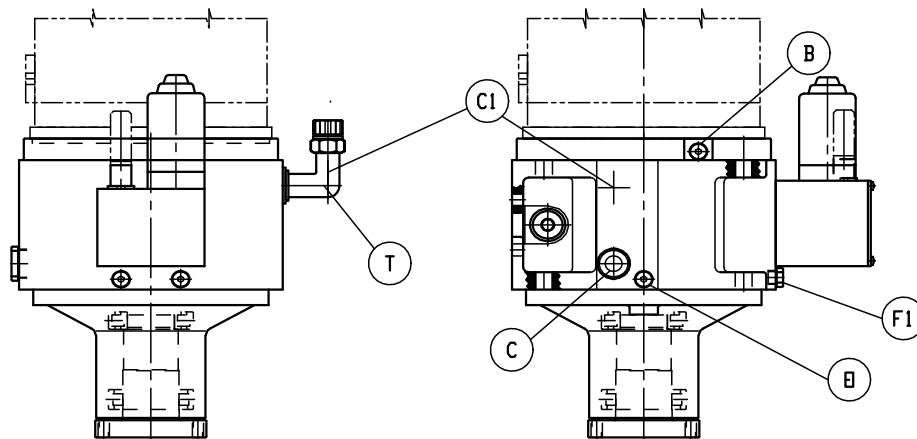

B = Oil suction for lubrication (1.5 l/min)

C = Oil recovery by falling

C1 = Vent valve position

F1 = To be plugged

E = Oil recovery by aspiration

T = Pipe for vent valve

To recover oil, connect the pipe to the oil drain hole C/C1. The pipe internal surface must be smooth enabling the oil to flow without difficulty and without creating an oil head in the gearbox (it is suggested to use a transparent pipe with internal diameter of 20 mm. minimum).



## 2.8 Gearbox motor connection and assembly

## 2.8.1 Gearbox connection and assembly to the motor (preferable solution)

This assembly system has to be used when the pinion (2) does not present special difficulties of assembling on the motor's shaft (assembly without interference or free)

- Verify the type of balancing of the motor's shaft

\* if with full key do not use the balancing key (22)

\* if with half key use the balancing key (22), which is supplied inserting it in one of the keyways present in the pinion (2)

- Position the motor's shaft with the key on the top

- With the gearbox complete assembled (included shaft and pinion) align the pinion's (2) keyway with the motor's shaft key (Ma)

- Approach all the parts to the motor fitting the pinion with the shaft and the key

- Pressure till the complete positioning of the flange with the motor

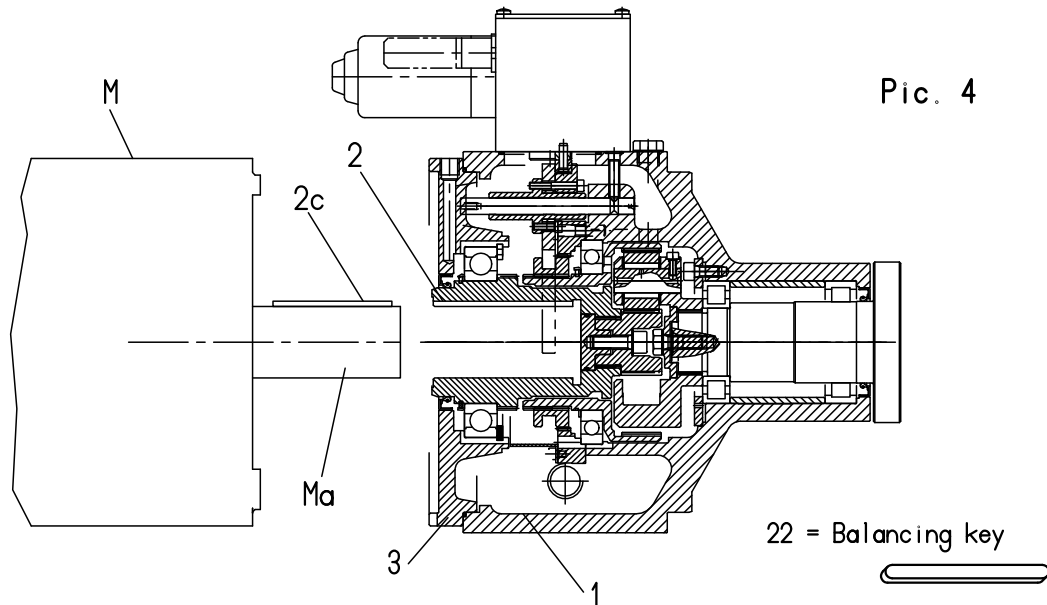

Pic. 4

22 = Balancing key

3 = Adapting flange

M = Motor

1 = Housing

2 = Pinion

2c = Motor's shaft key

Ma = Motor's shaft

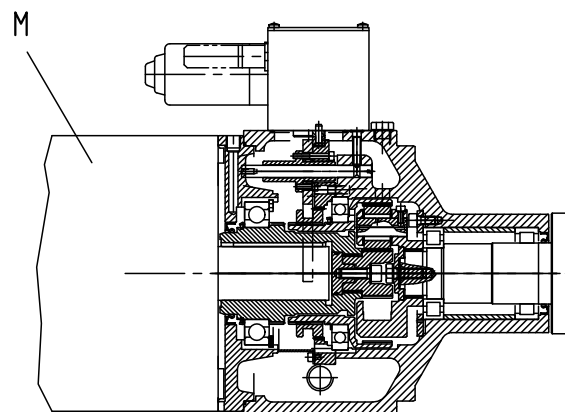

Pic. 5

Fit the gearbox with proper screws

For motors with fixing holes not in accordance with the gearbox holes.

For motors foreseen a double fixing (housing with flange and flange with motor)

## 2.8.2 Gearbox connection and assembly to the motor (alternative solution)

This assembly system has to be used when the pinion (2) presents special difficulties of assembling on the motor's shaft (assembly with interference)

- Verify the type of balancing of the motor's shaft
  - \* if with full key do not use the balancing key (22)
  - \* if with half key use the balancing key (22) which is supplied inserting it in one of the keyways present in the pinion (2)
- Position the motor's shaft with the key on the top
- After having taken the flange (3) complete with pinion (2) and o-ring align the pinion's keyways (2) with the motor's key (2c)
- Position the flange (3) with opening (\*) in direction of the actuator (100)
- Approach all the parts to the motor fitting the pinion with the shaft and the key
- Hammer the end of the solar gear (8) till the complete positioning of the flange with the motor

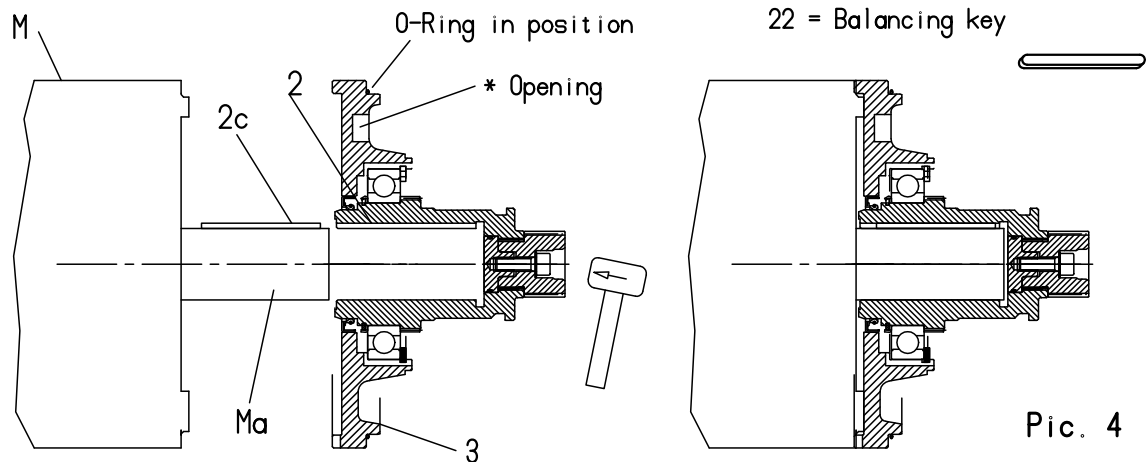

- Take and assemble the rest of the gearbox (housing...) paying attention to the fitting of the solar gear (8) with the planetary gear (10)

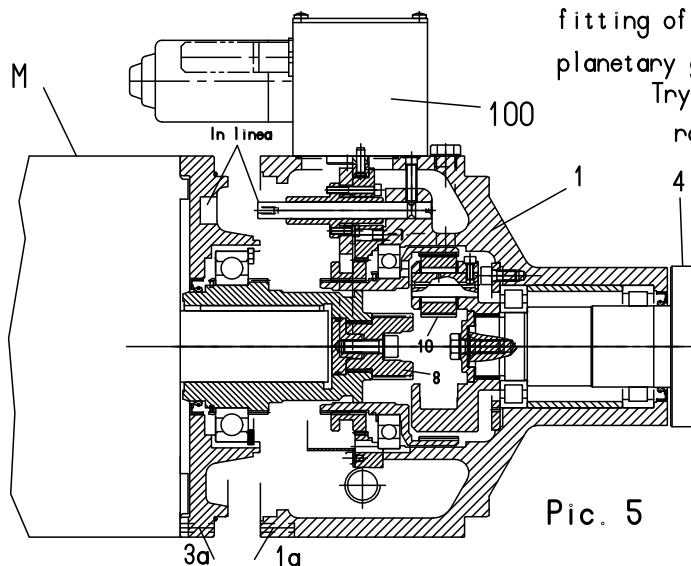

Try to facilitate operations by rotating the shaft (4); also keep aligned the holes (1a) and (3a)

- 3 = Adapting flange
- M = Motor
- 1 = Housing
- 2 = Pinion
- 2c = Key
- Ma = Motor's shaft

At completed approaching fix with screws the gearbox to the motor

For motors with with fixing holes not in accordance with the gearbox holes, is foreseen a double fixing (housing with flange and flange with motor).

## 2.9 Electrical section

## 2.9.1 Change gear flow cart

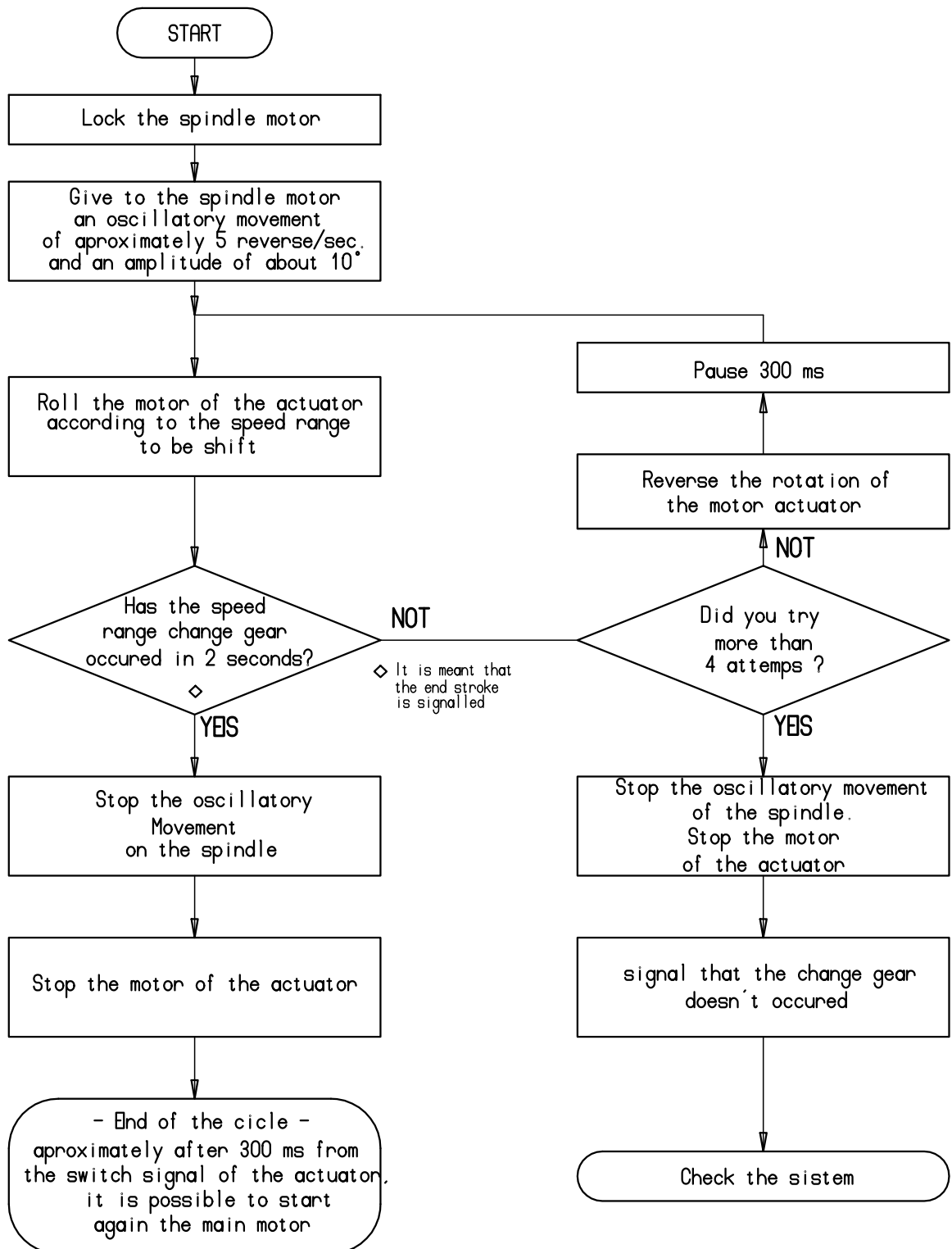

**NOTE:** If the speed range change gear has not occurred in the prefixed time a safety coupling of motor actuator slips.

## 2.9.2 Electrical wiring diagram

- Diagram of speed range change gear actuator: this solution avoid the lags due to the inertia of the motor actuator

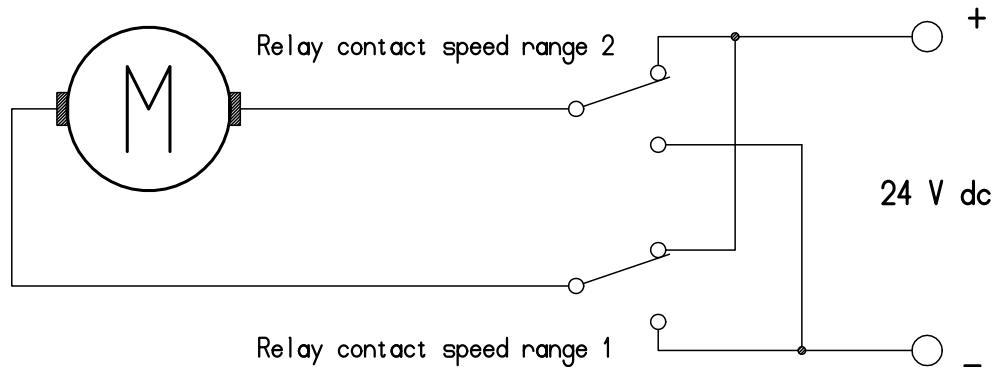

- Connections on the connector (103) of the actuator (100)

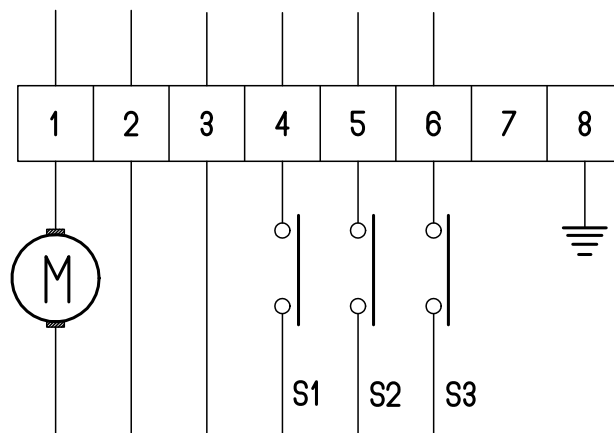

M = Motor actuator ( 24 Vcc 60 W )

S1 = limit switch range 1

S2 = limit switch range 2

S3 = free wheel position

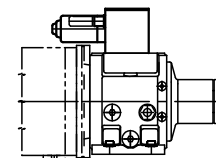

Standard solution

## 3.1 Lubrication and control

The gearbox is supplied without oil: before working it is necessary to provide to fill the gearbox with oil.



The oil has to have an ISO VG 68 viscosity compatible with the seals and a good resistance against the corrosion and wear.

Tab.6 Table of lubricant

Mobil	Agip	Esso	IP	BP
DTE oil Heavy Medium	OSO 68	TERESSO 68	TONNA oil T 68	ENERGOL HLP D 68

## 3.1.1 Horizontal assembling position type OPP and standard lubrication

The necessary quantity of oil is indicated in tab.7

Tab.7

Size	Oil quantity *
Horizontal	2.1 l
Vertical	2.8 l

These are just fiducial values, because it's necessary to check that the oil arrives at the middle of the oil level light. It is suggested to control the oil when the gearbox is not in function and if necessary provide to refill the same. Change the oil every 5000 hours and clean the magnetic plug which is on one of the discharge holes (A/A1).



## 3.1.2 Forced lubrication

The necessary oil flow is of 0,9-1,1 l/min. (20° C) at 2-3 bar

It is advised to use a oil-meter to secure the right flow

Tank volume 25 litres.

Sistematically check the oil deflux. It must be regular not to increase the quantity of oil inside the gear box. (The oil level must not exceed the middle of the outlet hole).



## 3.2 Failures research and repair

Each operation must be done with gearbox stopped and cold oil and surfaces



Irregularity	Possible cause	Inspection	Remedy
The signal of change of the speed doesn't arrive	Microswitch 125 broken	Verify manually that the microswitch changes status (open-closed)	Change the micro
	Worn micro push road 125	Verify that the micro is operated by the cam 112	Change the micro
	Operating cam backward		Approach the cam to the micro see chapter 3.2.3.
There is no change	Actuator motor(102) broken	Verify the integrity of the motor	Change the motor see chapter 3.2.1.
	No input to the motor (102)	Verify the correct input to the motor (24 V dc)	Restore the electrical input
	During a change the motor (M) hunting is missing	Verify that all phases of diagram are made 2.9.1	Restore all as per diagram at chapter 2.9.1.
	The torque of the safety coupling is not enough to make the change	With feeded motor (102) at (24 V dc) verify that after a phase of rotation of the gear (106) follows a phase at a slower speed	Restore the calibration of the safety joint: see chapter 3.2.2.
	The torque of safety joint is too high		

## 3.2.1 Change of the motor (102)

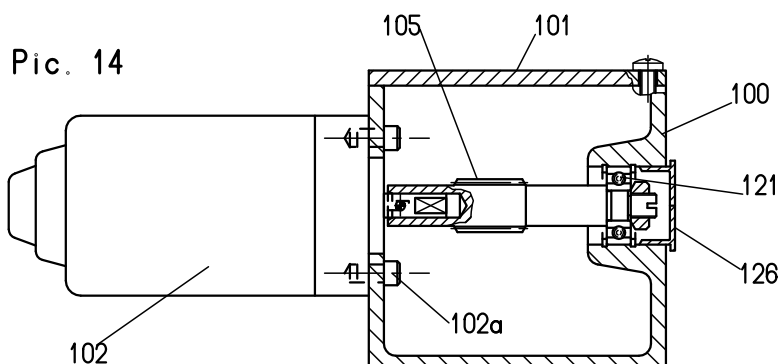

The motor (102) is fixed to the housing (100) with n°4 screws (102a).  
In order to get the screws it is necessary to remove:

- The worm screw (105)
- the gear (106)
- and all necessary parts which can be found in Pic 14 and Pic 15.

## 3.2.2 Safety joint calibration (belleville washers 123)

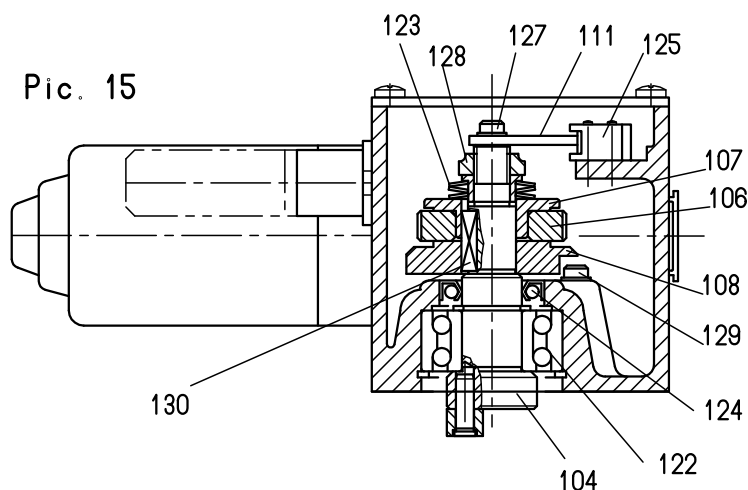

Feed the motor (102).  
Verify that the gear (106) at the beginning rotates, during the change, rotates quickly. At completed exchange the gear will be slowed down, therefore its movement will be slower (anyway it must slowly rotate till the motor is feeded).  
The calibration of the joint is made changing the pre-load of the belleville washers (123) (actuating the nut 128):

- the screwing of the nut determines the torque of the joint;
- the unscrew of the nut determines the reduction of the joint's torque

## 3.2.3 Adjustment of the cam which actuates the micro (111)

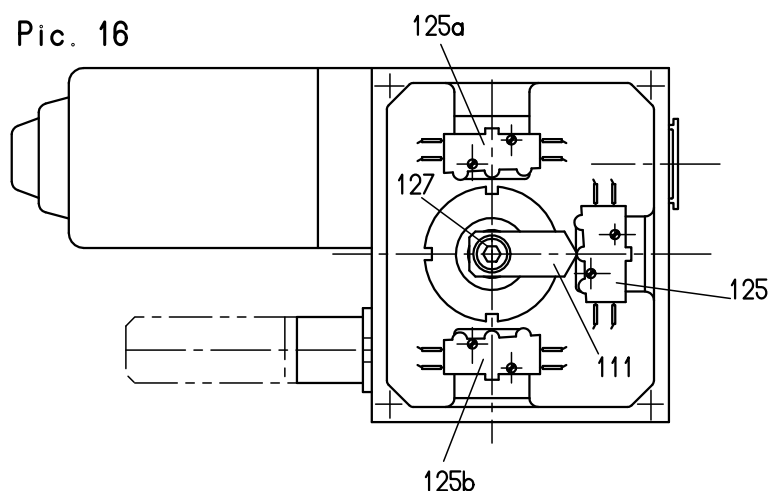

125 = Micro of neutral position  
125a = Micro 1 st speed (1/1)  
125b = Micro 2nd speed (1/4)  
111 = Cam  
127 = Cam locking screw

## 3.3 Assembly/disassembly

Any kind of disassembly operation has to be made with the gearbox is stillstand and with cold oil and cold surfaces



## 3.3.1 Gearbox-drawing

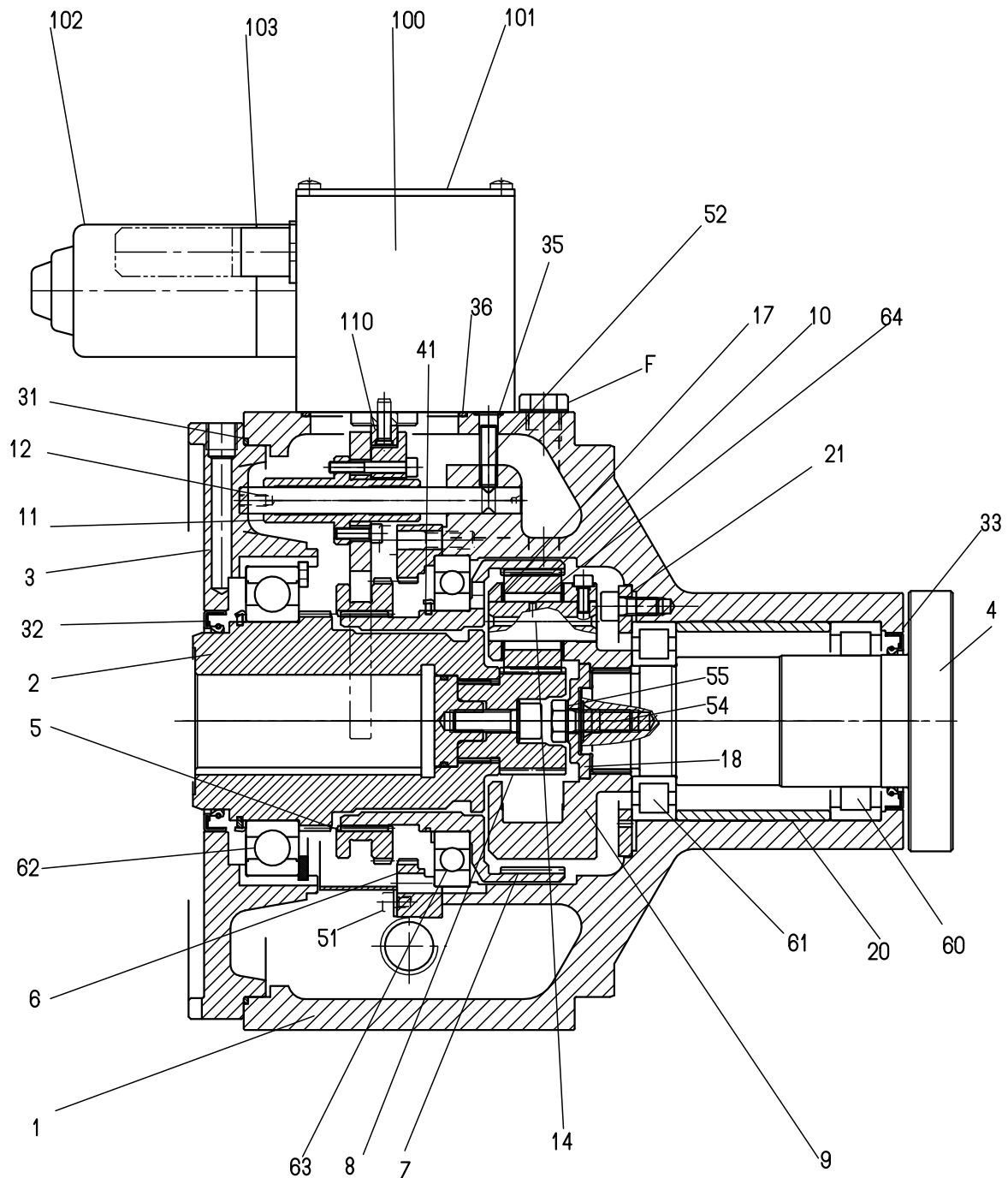

3.3.2 Actuator drawing

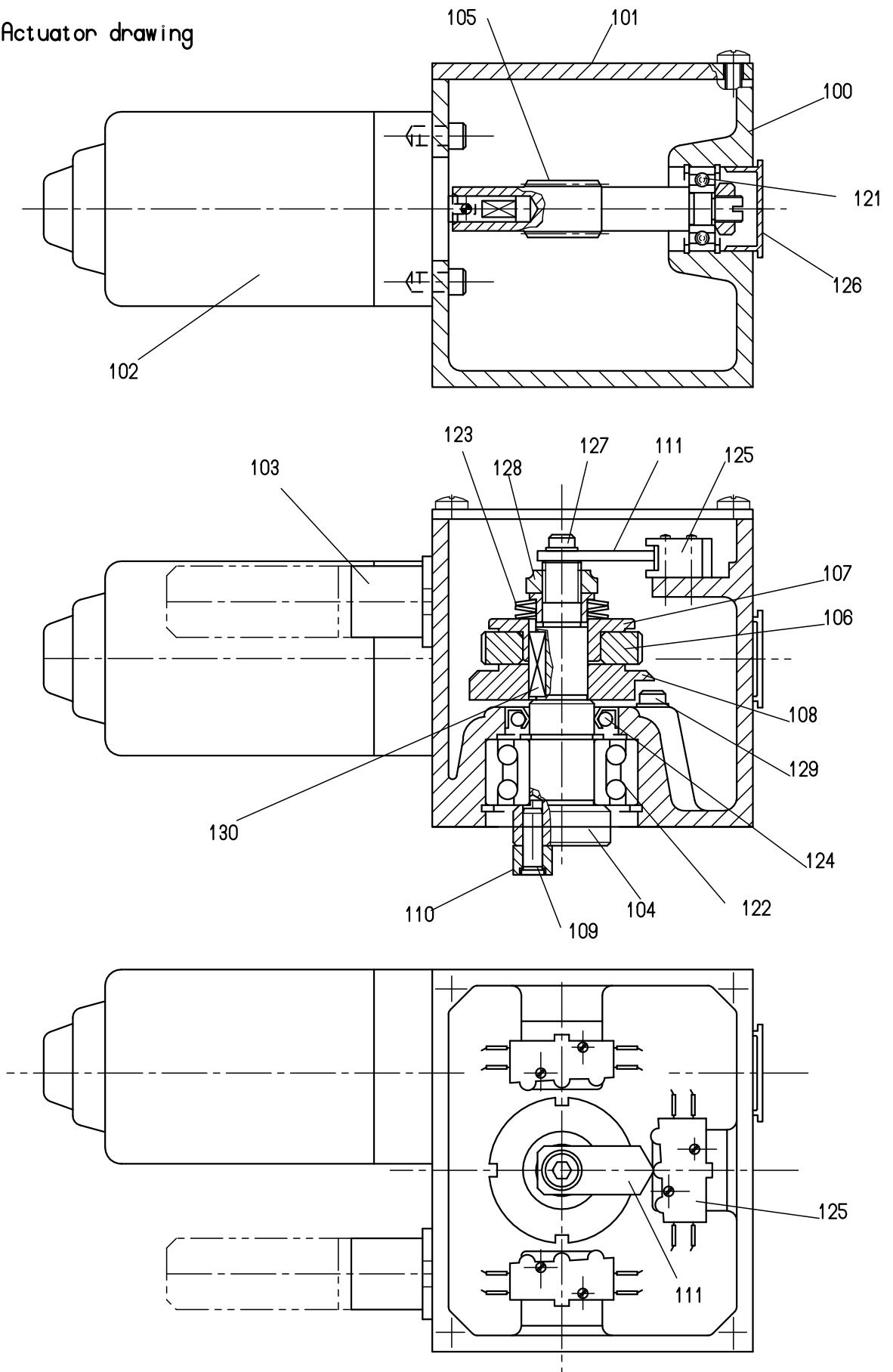

## 3.3.3 Disassembly/assembly of the actuator

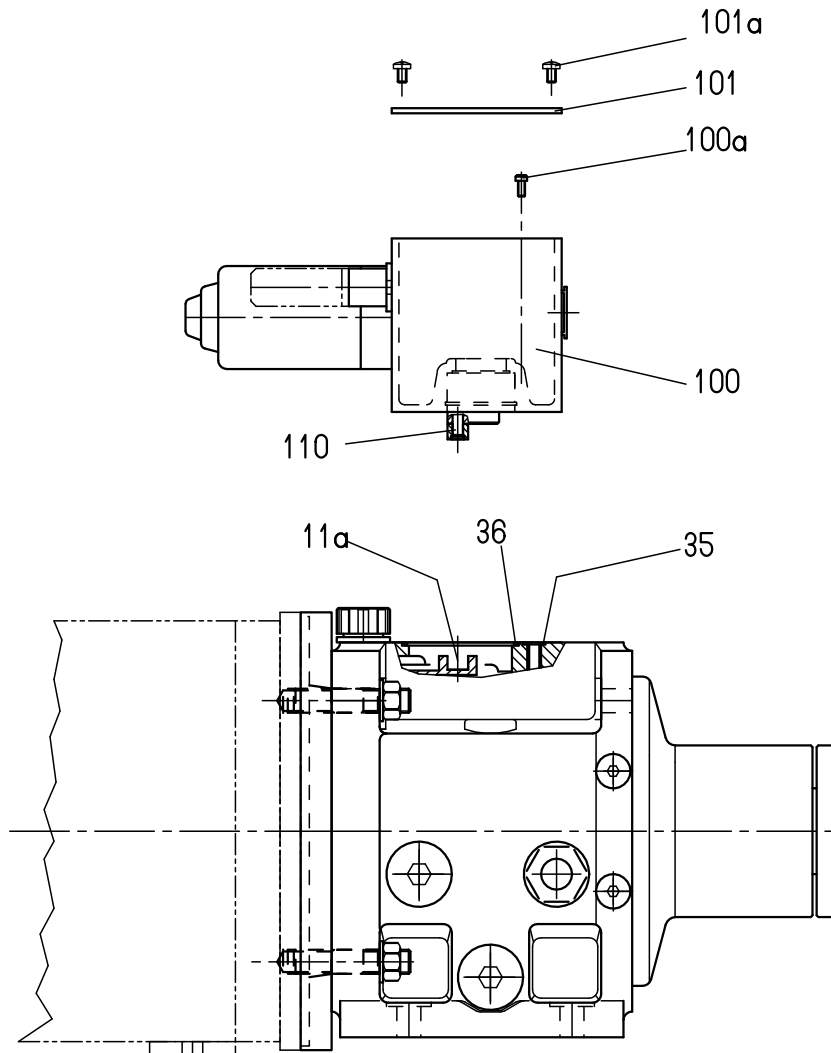

## Disassembly phases

- remove the screws (101a) and the cover (101)
- Unscrew the 4 screws (100a).
- Remove the complete actuator (100).

## When re-assembling:

- Be sure to keep the O-rings (35) and (36)
- Engage the key(110) in the seat (11a) of the fork



## 3.3.4 Disassembly/assembly of the motor flange

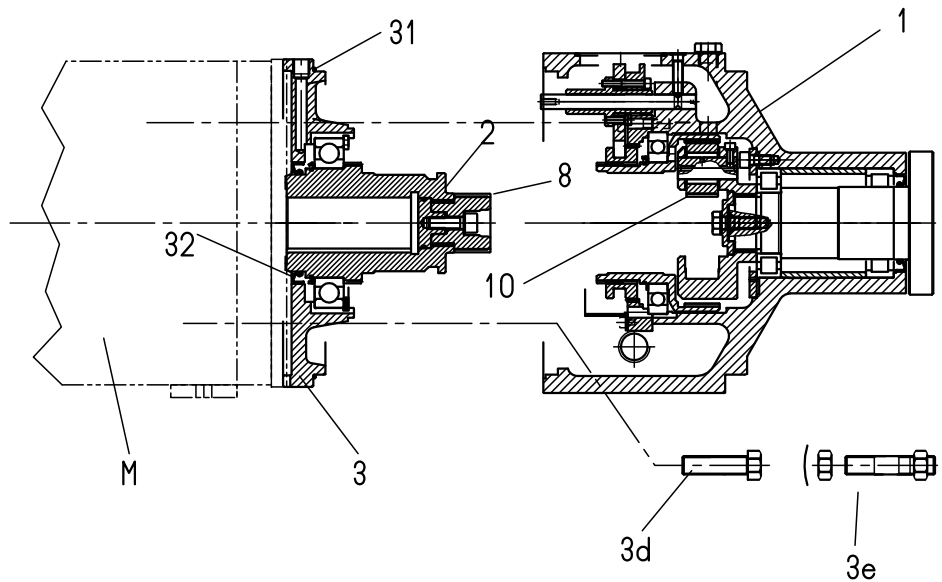

## Disassembly:

- Remove screws (3d) on the stud and nuts (3e)
- Take off the motor (M)-flange (3) unit

## Assembly:

- Check the following points:
- The o-ring must be in the right place
- The position of the fork and of the collar must be at slow speed (see chapter 2.5.3)
- Introduce the motor flange unit so that the broached end of the pinion fits the grooved part of the solar gear



## 3.3.5 Disassembly/assembly of the fork

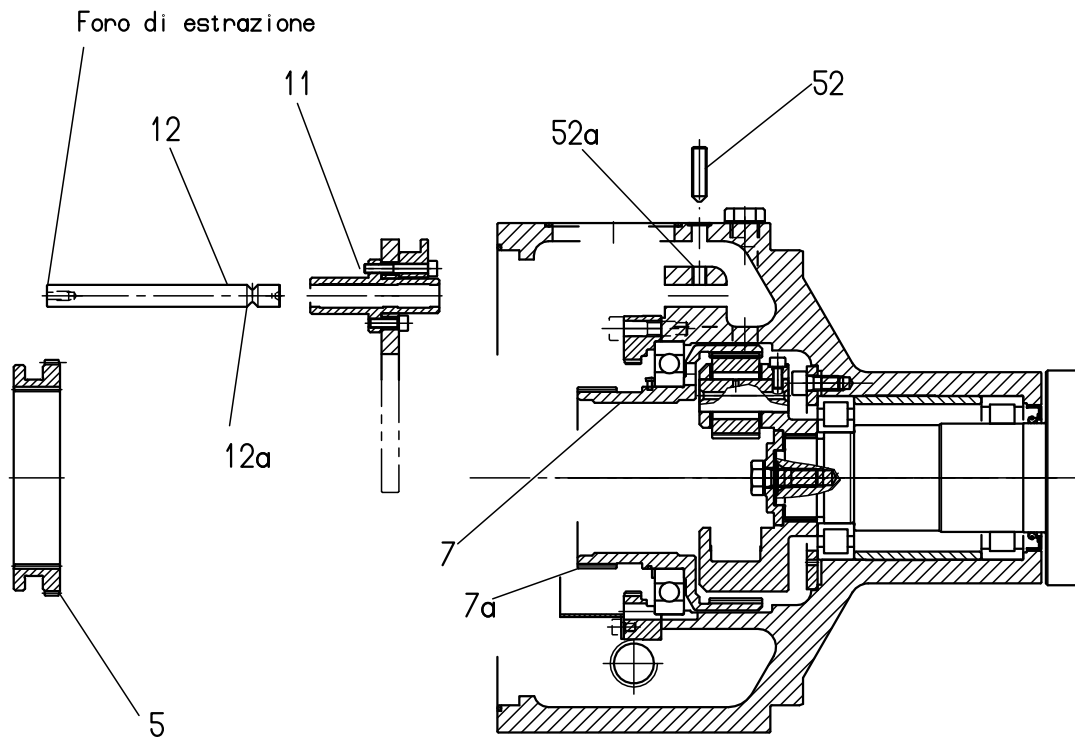

## Disassembly

- unscrew the lock bolt (52)
- Take off the pivot (12)
- Remove the fork (11) and the collar (5)

## Assembly:

- Insert the fork (11) on the collar (5). Engage the broached hole (5a) of the collar with the grooved part (7a) of the planetary gear (7)
- Insert the pivot (12) so that the groove (12a) reaches the hole (52a).
- Lock completely the bolt (52) using loctite.

## 3.3.6 Disassembly/assembly of the planetary gear

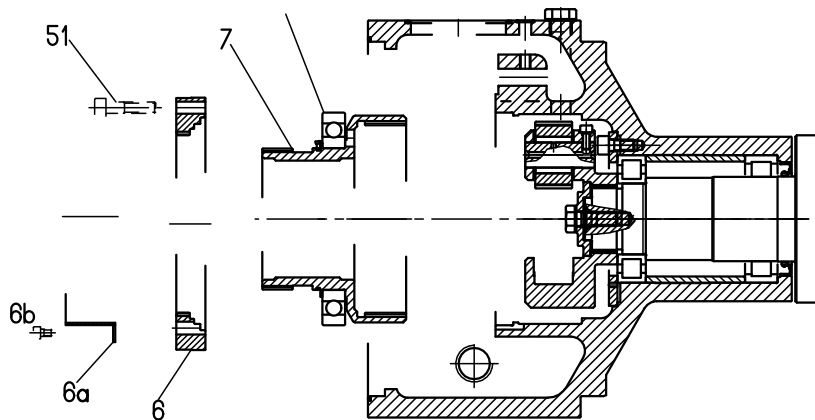

Disassembly:

- Remove screws (6b); remove the protection (6a)
- Remove screws (51); remove the toothed crown (6)
- Take out the planetary gear (7) complete with bearing (62)

## 3.3.7 Disassembly/assembly of the planetary gear unit (9-10)

and of the driving shaft (4)

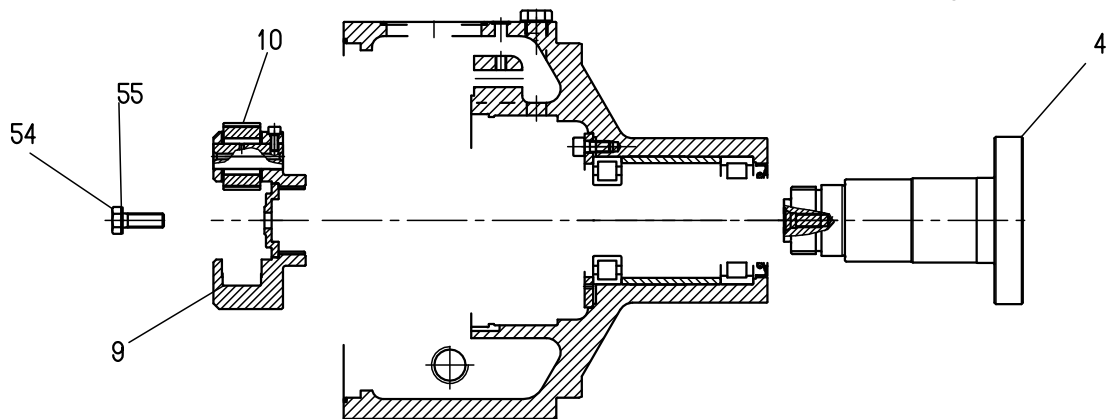

Disassembly:

- Remove the screw (54), take out the washer (55), extract the group (9-10)
- Remove the output shaft (4)

Assembly:

- Pay attention to not damage the rotating seal (33)
- Lock till and the screw (54) and brake with loctite 270 after having degreased both screw and threaded hole



## 3.3.8 Disassembly/assembly of the group pinion-solar gear

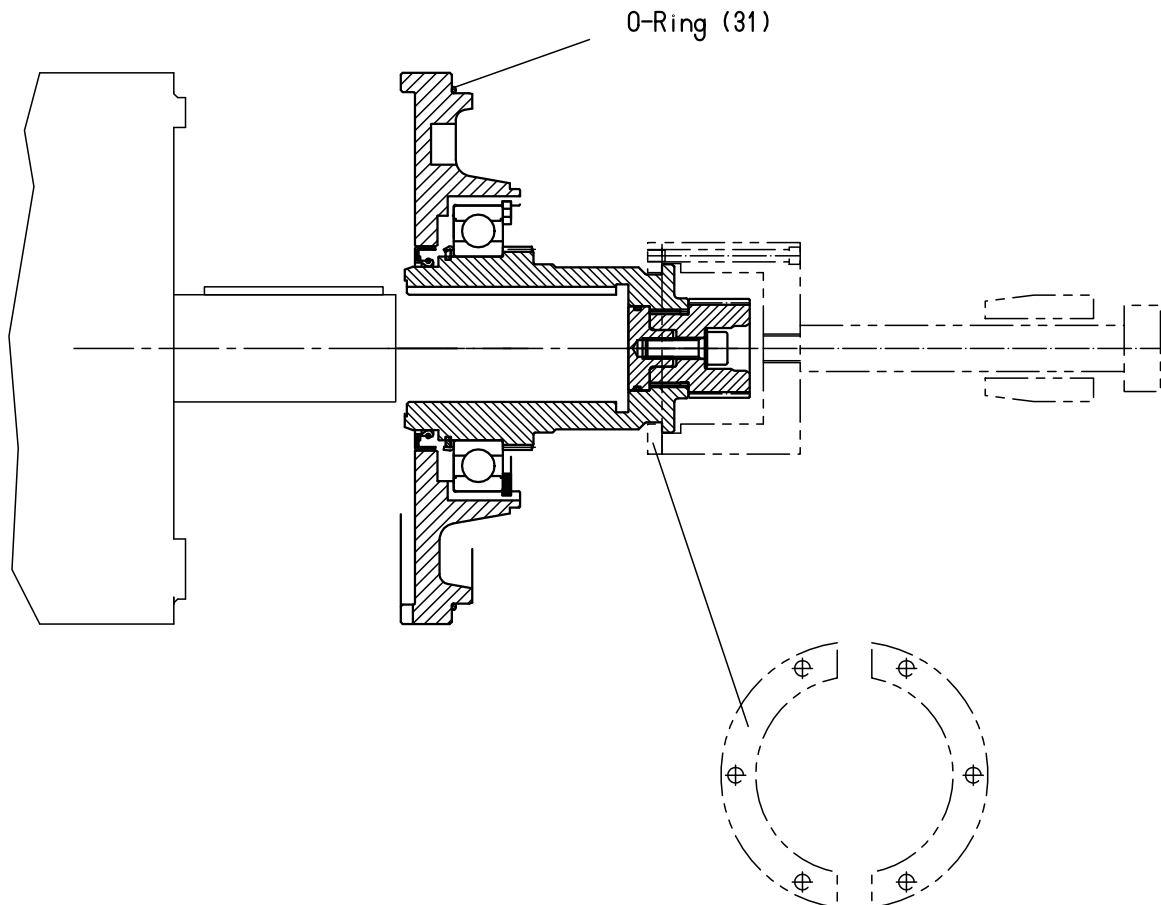

## Disassembly:

- In the case it should be difficult to extract the pinion from the motor's shaft use an extractor accordingly, as per indications in the picture

## Re-assembling:

- When re-assembling be sure of the presence of the o-ring (31)

## 3.3.8 Disassembly/assembly of the planetary gears

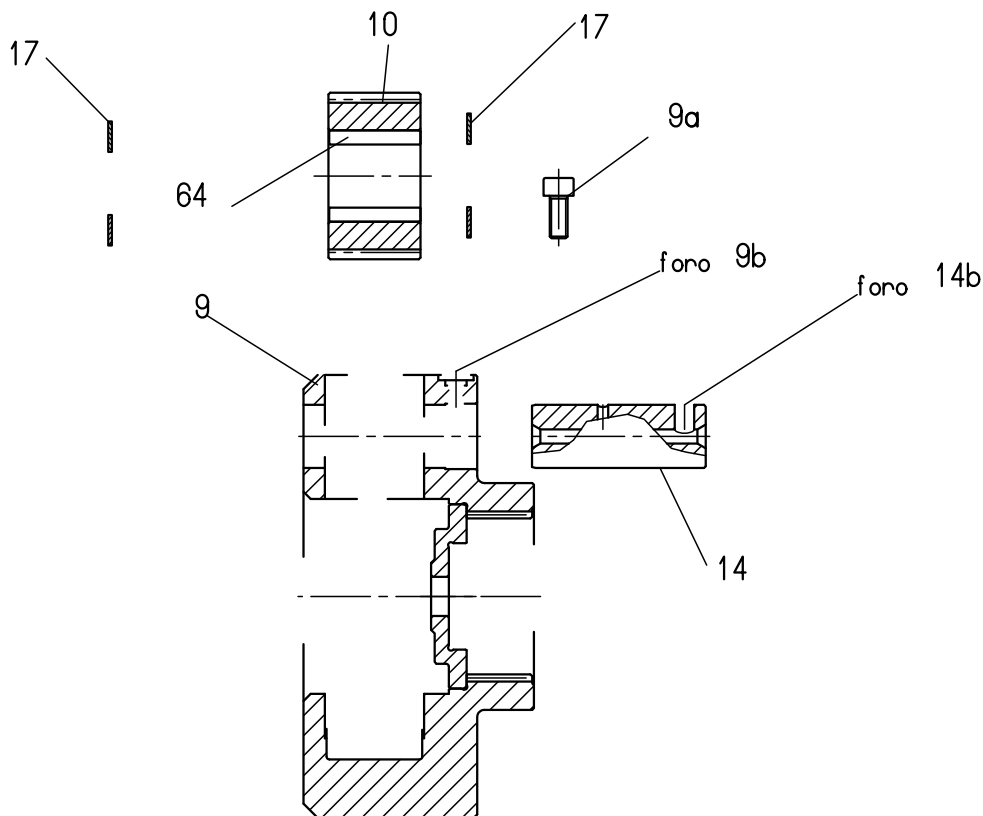

## Disassembly:

- Remove screws (9a)
- Remove pivots (14) from planetary gears carrier (9)
- Take out planetary gears (10) complete with needle rollers (64) and thrusts

## Re-assembling:

- Grease needle rollers with thick grease
- Turn pivots (14) so that holes (14b) coincide with the holes (9b) of the planetary gears carrier (9)

Control that the number of needle rollers (64) per each planetary gear (10) coincides with the indicated in the chapter 3.4.1 and 3.4.2 (spare-parts list)



3	Maintenance	Gearbox type CE	CE002-e
---	-------------	--------------------	---------

3.4 Spare-parts schedule  
3.4.1 Spare-parts schedule -CE13-

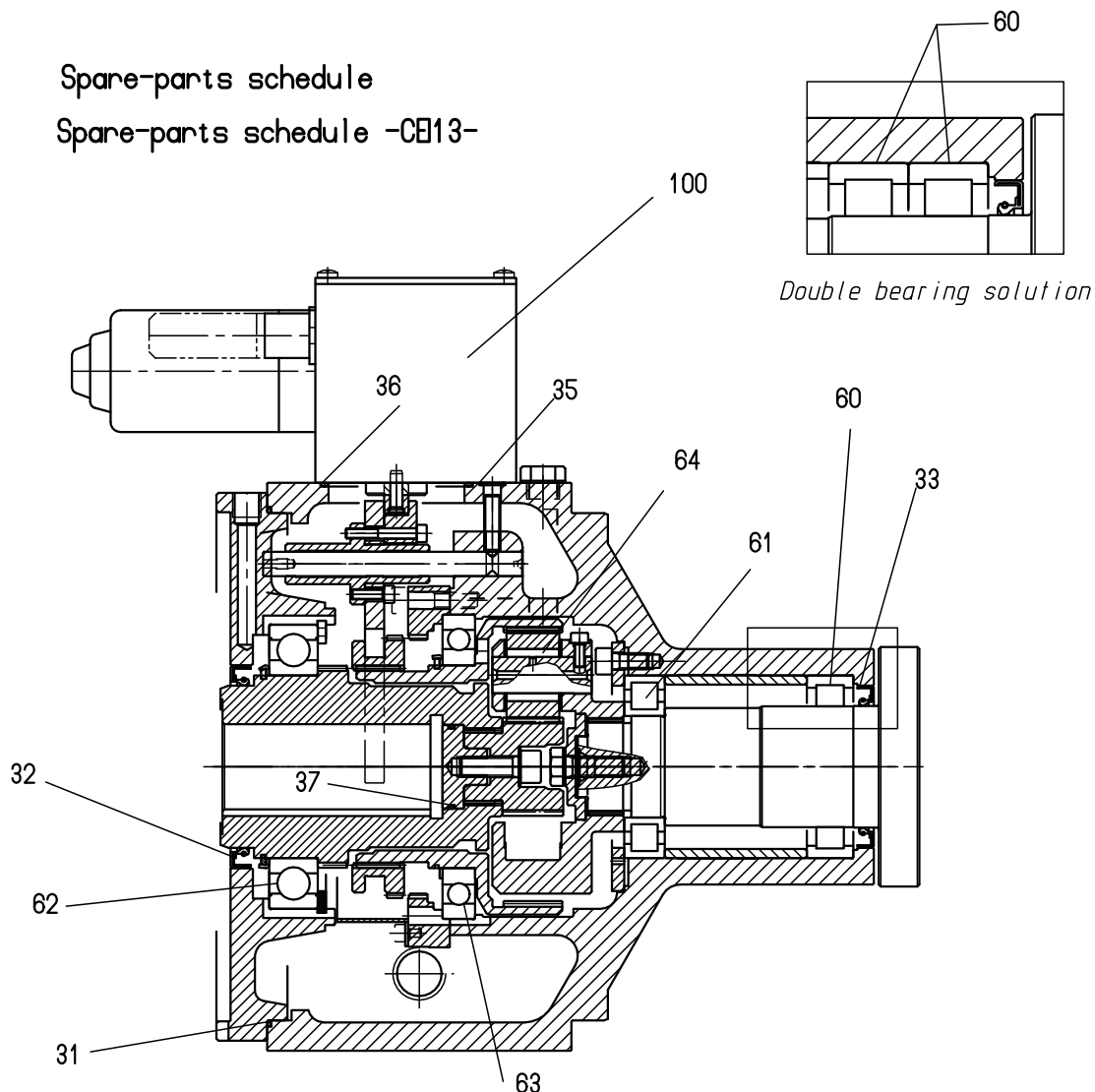

N°	Code	Description	Type	Q.ty
31	999.223.00097	O-ring	OR 178	1
32	999.263.07374	Shaft seal	A 8010010 Viton	1
33	999.224.07317	Shaft seal	A 608008 Viton	1
35	999.223.00792	O-ring	OR 012	1
36	999.223.07384	O-ring	OR 149	1
37	999.223.03436	O-ring	OR 127	1
60	999.149.07238	Roller bearing	NU 2210 ECP (without internal thrust)	1
61	999.149.07593	Roller bearing	NUP 210 ECP	1
62	999.149.07543	Sphere bearing	6018	1
63	999.149.07272	Sphere bearing	16020	1
64	999.149.07592	Rollers	NRO B 4x25.8.8G2	17x4
100	23.0000.100.01	Drive unit		1



## 3.4.2 Drive unit spare-parts schedule -CE12 / CE13 / CE14-

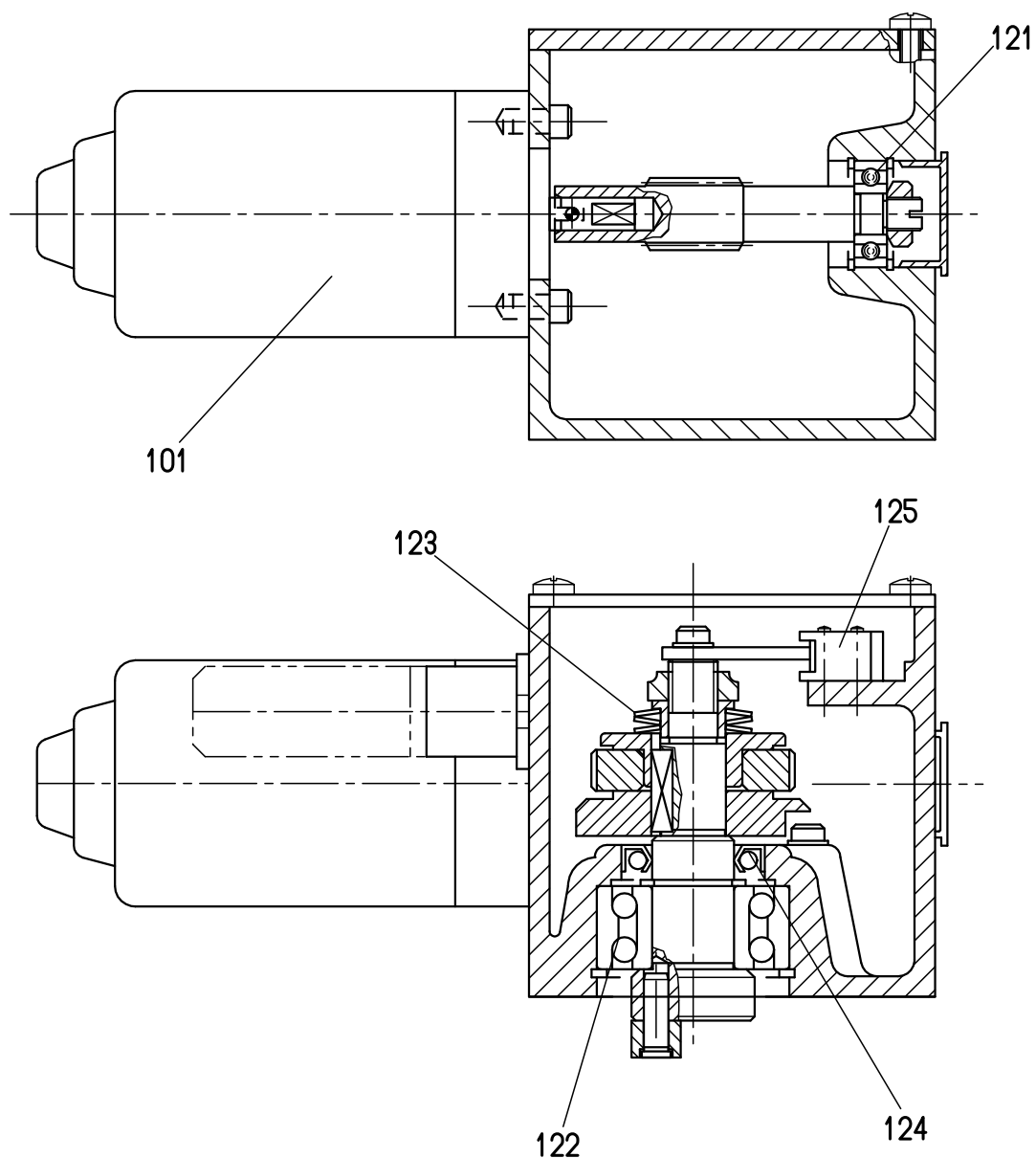

N°	Code	Description	Type	Q. ty
101	23.0000.114.01	Engine		1
121	999.148.07229	Sphere bearing	6000	1
122	999.149.03651	Double bearing	3204	1
123	999.210.01933	Belleville washer	34x16.3x1.5	3
124	999.226.07497	Shaft seal	A 20357	1
125	999.295.06893	Micro-switch	83106-OCW3 Crouzet	3